

Coaxial High Directivity Directional Coupler

ZHDC-16-63+

50Ω 16 dB Coupling 50 to 6000 MHz

Maximum Ratings

Operating Temperature	-40°C to 85°C
Storage Temperature	-55°C to 100°C

Coaxial Connections

INPUT	1
OUTPUT	2
COUPLED	3

Outline Drawing

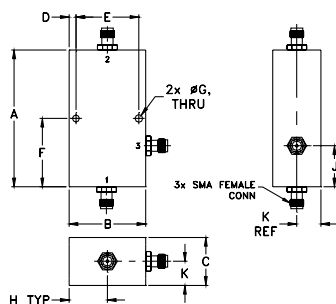

Outline Dimensions (inch/mm)

A	B	C	D	E	F
2.50	1.4	0.88	0.13	1.15	1.25
63.50	35.56	22.35	3.30	29.21	31.75
G	H	J	K		wt
0.14	0.7	0.75	0.44		grams
3.56	17.78	19.05	11.18		100.0

Electrical Schematic

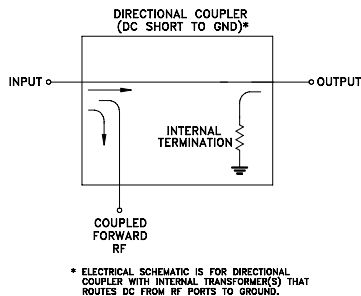

Features

- wideband, 50 to 6000 MHz
- high directivity, 32 dB typ.
- flat coupling, ±0.45 dB typ.
- good VSWR, 1.20:1 typ.

Applications

- military defense
- test and measurement
- laboratory use



CASE STYLE: FM1918

Connectors	Model	Price	Qty.
SMA	ZHDC-16-63-S+	\$259.95 ea.	(1-9)

+RoHS Compliant

The +Suffix identifies RoHS Compliance. See our web site for RoHS Compliance methodologies and qualifications

Electrical Specifications at 25°C

Parameter	Condition (MHz)	Min.	Typ.	Max.	Unit
Frequency Range		50	—	6000	MHz
Mainline Loss	50 - 6000	—	2.0	3.0	dB
Coupling	50 - 6000	15.5	16.7	17.5	dB
Coupling Flatness(±)	50 - 6000	—	0.45	0.9	dB
Directivity	50-3000 3000-6000	26 24	32 30	—	dB
Return Loss (Input)	50 - 3000 3000-6000	—	24 22	—	dB
Return Loss (Output)	50 - 3000 3000-6000	—	21 18	—	dB
Return Loss (Coupling)	50 - 3000 3000-6000	—	18 17	—	dB
Input Power	50 - 6000	—	—	0.5	W

Typical Performance Data

Frequency (MHz)	Mainline Loss (dB) In-Out	Coupling (dB) In-Cpl	Directivity (dB)	Return Loss (dB)		
				In	Out	Cpl
50	1.47	16.54	33.07	42.34	39.93	27.52
100	1.49	16.78	37.54	40.29	37.22	23.79
500	1.58	17.13	39.79	33.74	29.44	20.72
1000	1.66	17.14	36.11	34.49	30.93	19.34
2000	1.83	16.94	38.05	28.16	22.70	18.07
2750	1.98	16.77	33.34	33.94	22.85	17.86
3000	2.02	16.69	32.84	36.11	23.85	17.17
3500	2.09	16.65	32.79	40.38	23.72	17.73
4000	2.14	16.61	31.16	44.83	22.99	17.44
5000	2.29	16.43	29.68	34.91	18.62	19.10
6000	2.41	16.31	35.60	25.26	16.64	18.56

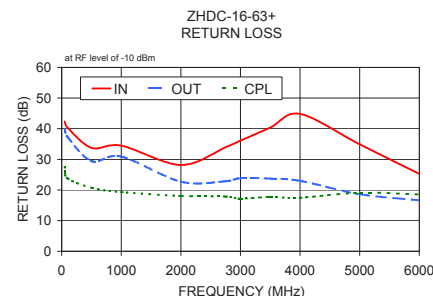
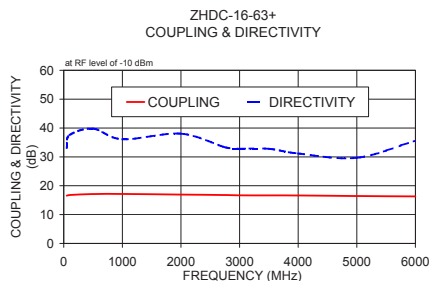
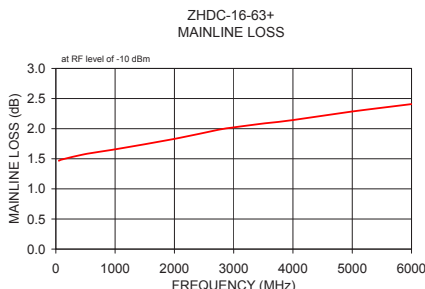

Notes

- Performance and quality attributes and conditions not expressly stated in this specification document are intended to be excluded and do not form a part of this specification document.
- Electrical specifications and performance data contained in this specification document are based on Mini-Circuit's applicable established test performance criteria and measurement instructions.
- The parts covered by this specification document are subject to Mini-Circuits standard limited warranty and terms and conditions (collectively, "Standard Terms"); Purchasers of this part are entitled to the rights and benefits contained therein. For a full statement of the Standard Terms and the exclusive rights and remedies thereunder, please visit Mini-Circuits' website at www.minicircuits.com/WCLStore/terms.jsp

